

The Atlas Copco logo is displayed in white text on a blue rectangular background. The logo consists of the company name "Atlas Copco" in a serif font, with two horizontal white bars above and below the text.A technical drawing overlay is positioned in the bottom-left corner of the page. It features a circular cross-section of a pipe or vessel with various dimensions and labels such as "1380 (R4-3)", "1830 (R4-2)", "C-C (1/3)", "Ø22", "Ø27.8", "Ø22", "10.5", "18.5", "30.8", and "14.8".

# The P.R.I.C.E. Benefits of On-Site Nitrogen

## Introduction

If your business is a regular consumer of nitrogen, you're likely (and perhaps even painfully) aware of what a hassle nitrogen-tank rental and delivery can present. Those bulky nitrogen cylinders take up a lot of floor space in your facility, and being such heavy vessels containing gas under high pressure, they amount to an ever-present safety risk. Further, the rental/delivery service can be very expensive, tank replacement regularly leads to downtime and added labor costs, the gas company's strict contracts can be a challenge to get out of ... and the list goes on.

If any of the issues mentioned above sound familiar to you, you're not alone. Like many business owners and workers in similar situations have already done, it may be time for you to consider on-site nitrogen generation.

The good news about generating on-site nitrogen is that if you already have an air compressor, you're halfway there. All you need is a connected nitrogen generator unit to generate your own nitrogen in-house. There are two main types of on-site nitrogen generators: PSA (Pressure Swing Adsorption) and Membrane. Both work in very different ways, but let's not explore which is right for you just yet – let's focus on the benefits of on-site nitrogen generation.

**P.R.I.C.E.**



## Purity Control

Tanked nitrogen is 99.99% pure, which is great — when it's needed. The nitrogen is delivered at that ultra-high purity level because the gas company produces a single variety for all of its customers, regardless of what level of purity each individual customer needs. But for approximately 75% of consumers who buy tanked nitrogen, this high level of purity isn't required for their applications. One reason for the high cost of 99.99% pure bottled nitrogen is that a very large system is required to produce this level of purity, so the output gas tends to follow a one-purity-fits-all formula.

With on-site nitrogen generation, consumers can get nitrogen at the exact purity level needed, often at a significant cost savings when compared to the cost of the highly pure tanked nitrogen. In fact, the tank needed to produce nitrogen at a 99.99% purity level is roughly 10 times as large as the tank needed to produce nitrogen at a 95% purity level — and the smaller tank can be as much as \$10,000 cheaper than the one needed to reach the higher purity levels. The bottom line: If your application's oxygen tolerance is high, you don't need to be paying a premium for nitrogen that is nearly 100% pure. A lower purity level would meet your needs and save you money. The applications for which lower-purity nitrogen might be perfect include tire filling, fire suppression, certain types of food packaging, laser cutting, electronic soldering, plastic extrusion and more. In fact, most applications don't require 99.99% pure nitrogen. However, let's be clear — even with a 99.99% purity level, on-site nitrogen still offers a clear payback and an ROI that makes perfect sense for the business plan. Of course, the lower the required nitrogen quality, the bigger the payback — but there is a significant payback regardless of the purity level needed.

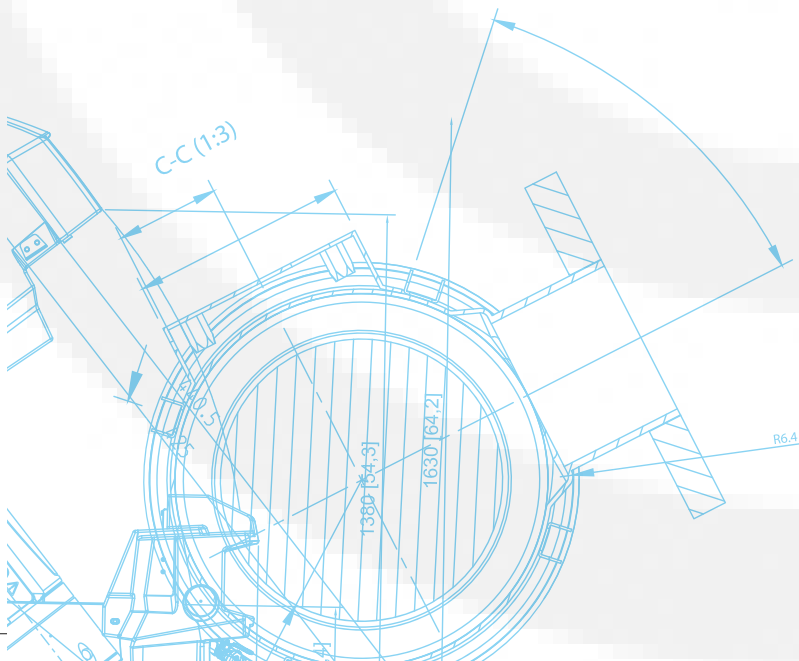



## Reductions

When a business implements on-site nitrogen generation, the reductions it can realize include:

- **Reduced downtime:**  
Because a nitrogen generator is constantly available and its tank is always being refilled, there's no need to switch out cylinders, resulting in downtime reductions.
- **Reduced labor:**  
On the same note as the item above, because the need to switch out tanks regularly is eliminated, the labor costs involved in doing so are also eliminated.
- **Reduced injuries:**  
Since there is no longer a need to switch out and move the heavy nitrogen cylinders, the risk of injuries is greatly reduced.
- **Reduced need for storage space:**  
With just a single tank on-site that is constantly being refilled, there's no longer any need to store extra tanks in the facility, freeing up valuable space for other purposes.
- **Reduced waste:**  
Because on-site generation can produce nitrogen at exactly the needed pressure and flow rate, no gas is bled off in effort to get the gas to these required levels. Also, with cylinder-rental services, the tanks are often returned with some gas left in them — which can add up to large amounts of wastage over time, especially for businesses that utilize nitrogen in high quantities. Further, when a tank is not being used for long stretches of time, the pressure builds — creating a need for the relief valve to bleed off nitrogen gas, wasting a costly (and already paid-for) resource in the process.



## Increased Safety

Typical nitrogen-delivery services utilize cylinders that weigh over 100 pounds and that are filled with gas under high pressure — so it's not hard to imagine why safety directors can't help but see a recipe for a highly dangerous projectile, especially should a valve be broken off. Further, when nitrogen is delivered in liquid form, a high risk for burns can exist.

When nitrogen gas is produced on-site, the risks of both burns and projectiles is greatly decreased, as the holding tank for the nitrogen is stationary — largely eliminating the risks involved with moving the cylinders from place to place.



## Cost Savings

On-site nitrogen generation can produce cost savings in a number of ways, leading to an increase in ROI for business owners. The most obvious example is that generating nitrogen allows business owners to eliminate rental fees on cylinders. These can add up, as most shops generally have three rented cylinders in-house — one in use, another empty tank awaiting pickup, and a third one full and waiting to be rotated into use. With on-site generation, of course, just one owned cylinder is needed on-site, and it's constantly being refilled.

Next, when cylinders are rented, there will inevitably be cases when the tanks are returned with unused nitrogen remaining inside — representing waste losses in gas that was paid for but never used. Another consideration, as mentioned above, is that cost savings can be realized when nitrogen of lower purity levels is used for applications with higher levels of oxygen tolerance. More opportunities for cost savings include avoiding any combination of the following: the uncontrollable price increases that can come with purchased gas, avoiding costly contract negotiations, eliminating or reducing hazardous material fees, avoiding delivery surcharges, and reducing the amounts of local and state taxes paid.



## Efficiency/Environment

On-site production creates efficiencies and environmental benefits by effectively eliminating both the production and delivery phases needed for each delivered cylinder, as it eliminates the need to burn energy in converting nitrogen gas to liquid, and it reduces the carbon dioxide emissions generated by delivery vehicles. In addition, by avoiding the return of partially filled tanks, as well as any necessary gas bleed-off/venting before tank return, on-site nitrogen generation reduces waste right at the facility.

If you're still having nitrogen cylinders delivered to your business — and especially if you're a heavy nitrogen consumer who sees regular tank drop-offs/pickups at your facility — it may be time to consider all the P.R.I.C.E. related benefits that on-site nitrogen generation can bring. For many business, the ROI reaped from on-site generation can cover the initial equipment investment very quickly, all while introducing a range of benefits and conveniences.

To learn more about generating nitrogen on-site at your facility — while both saving money and reducing downtime — visit [www.atlascopco.com](http://www.atlascopco.com) or call Atlas Copco at 866-546-3588. We offer a range of reliable gas generators that can efficiently and effectively meet all of your nitrogen and oxygen on-site production needs.



Atlas Copco Compressors LLC  
[atlascopco.com/air-usa](http://atlascopco.com/air-usa)

### P.R.I.C.E. Benefits Summary:



#### Purity Control

Set the purity level that you need and only pay for that purity.



#### Reduce Wastage

You use every drop you produce. Nothing gets sent back.



#### Increase Safety

No delivery, storage or movement of high-pressure cylinders.



#### Cost savings

Reduce the cost of your nitrogen by up to 80%.



#### Environment

No reportable transportation to your site. No need to bleed-off/vent tanks before returning.

