

Tile Roof 4 Panels Mounting Kit



Features

High snow load capacity

Designed to withstand high snow loads, ensuring durability and safety.

Corrosion Resistance

The high corrosion resistance of the materials used ensures a long service life.

Energy cost savings

Helps reduce reliance on conventional power sources and lower monthly utility bills.

Strong weather resistance

Wind-resistant, rain-resistant, and resistant to extreme temperatures.

Safe and reliable

The robust structure ensures the solar panels are securely in place.

Specification

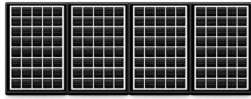
System Series	Solar Tile Roof Mounting Kit - 4 Panels
Application	Pitched Tile Rooftop
Tile Angle	Parallel to roof slope
Wind Load	<80m/s
Snow Load	Up to 1.4 kN/m ²
Solar Module	30mm Height Frame or Frameless panel
Panel Layout	
Design Standard	AS/NZS 1170 / JIS C8955-2017 and other international standards
Material	Aluminum & Stainless Steel
Color	Silver
Warranty	10 years warranty and 25 years service life

Components

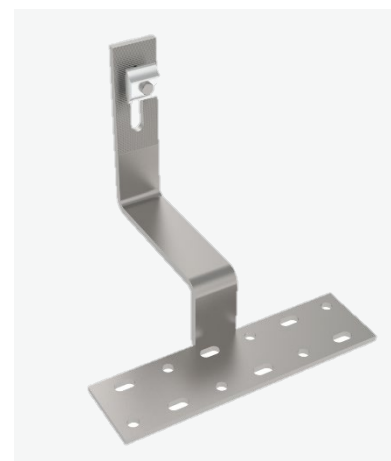

Hook X 10

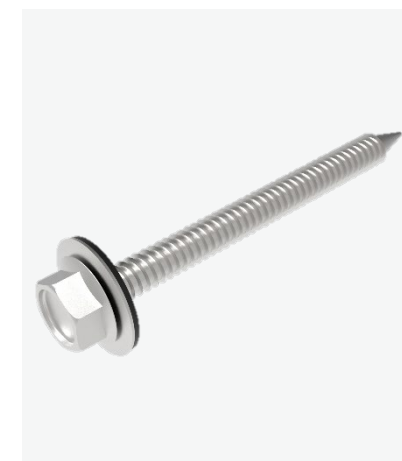

Wood Screw X 30



Middle Clamp X 6



End Clamp X 4



Rail not included

Installation

